

2UCD074000E002\_D

# PCS100 AVC-40

## Active Voltage Conditioner

### Technical Catalogue





## ABOUT THIS DOCUMENT

### ABB Power Conditioning

Leading the industry in innovation and technology, ABB provides power conditioning for many of the world's foremost organizations, ensuring the continuous operation of small, medium to large businesses are protected on a global scale.

ABB's Power Conditioning portfolio is a unique line up of low and medium voltage power conversion technology that is part of the product group, Power Protection.

The portfolio consists of static frequency converters, UPSs, voltage and power conditioners that demonstrate highly reliable and cost-effective performance. With this product portfolio, ABB offer efficient power conditioning solutions that are specifically designed to solve power quality problems and stabilize networks.

Covering applications from data centers through to complete industrial plant protection, micro grid systems and shore-to-ship supply, ABB have the power conversion technology for every need. Starting from a few kVA to many MVA and a wide range of supply voltages.

It's business as usual with power conditioning technologies in place

### Power Conditioning Product Portfolio

Product Line	Typical Problems	Product
Industrial UPS	Utility deep sag and surge correction	PCS100 UPS-I Industrial UPS
	Utility outage protection	HiPerGuard MV UPS
Voltage conditioning	Utility sag and surge correction	PCS100 AVC-40 Active Voltage Conditioner for sag correction
	Load voltage regulation	PCS100 AVC-20 Active Voltage Conditioner for voltage regulation
Frequency Conversion	50/60 Hz conversion	PCS100 SFC Static Frequency Converter
	Frequency fluctuation	SureWave SFC



---

## Document Information

### Copyright notice

The information in this manual is subject to change without notice. This manual and parts thereof must not be reproduced or copied, or disclosed to third parties, nor used for any unauthorized purpose without written permission from ABB Ltd. The hardware and software described in this manual are provided under a license and may be used, copied, or disclosed only in accordance with the terms of such license.

### Document identification

Ownership: ABB Ltd., Power Conditioning Products  
Document number: 2UCD074000E002  
Issue date: 31/03/2022  
Revision: Rev D

### Contact information

Address: ABB Ltd. 111 Main North Road, Napier, New Zealand.  
Website: <https://new.abb.com/ups>

# Contents

<b>About This Document</b> .....	<b>2</b>
ABB Power Conditioning.....	2
Power Conditioning Product Portfolio .....	2
Document Information.....	3
<b>Voltage Sags – The Problem</b> .....	<b>6</b>
<b>PCS100 AVC-40 Active Voltage Conditioner</b> .....	<b>7</b>
How it works.....	7
<b>PCS100 AVC-40 Benefits</b> .....	<b>8</b>
Reduce the cost of sag events.....	8
Improve plant operation .....	8
Faster return on investment .....	8
Reduce damage to equipment.....	8
<b>Industries and Applications</b> .....	<b>9</b>
<b>Features</b> .....	<b>10</b>
No energy storage.....	10
Very high efficiency .....	10
Continuous online regulation.....	10
Industrial design .....	10
Small footprint .....	10
Regenerative load support .....	10
Internal bypass.....	10
Connectivity.....	10
Modular construction .....	10
Sophisticated control software.....	10
<b>Functional Description</b> .....	<b>11</b>
PCS100 AVC-40 Correction Capabilities.....	11
PCS100 AVC-40 Performance Curve .....	12
PCS100 AVC-40 Operation Details.....	13
<b>Technical Specification</b> .....	<b>15</b>
<b>How to Select a PCS100 AVC-40</b> .....	<b>17</b>
Type Code.....	17
Type Code Parameters: .....	17
PCS100 AVC Sizing Tool .....	17
<b>PCS100 AVC-40 Model Range</b> .....	<b>18</b>
<b>Layout Plans and Dimensions</b> .....	<b>19</b>
Layout Plans.....	19
Clearance.....	23
Weights .....	23
<b>Options</b> .....	<b>24</b>
Back-to-back Layout (BB) .....	24
Side Aperture (SA) .....	24
Roof Kit (RK).....	25
Top Entry Cable Duct (CD).....	25
Termination Enclosure (TE).....	26
Dummy Enclosure (DMY).....	26
Termination Palms (TPx).....	27
Redundant Power Supply Unit (PS).....	27
<b>User Interface</b> .....	<b>28</b>
Graphic Display Module.....	28
Remote Monitoring .....	28
Remote Web Pages.....	29

Modbus TCP.....	29
E-mail.....	29
<b>User Connections.....</b>	<b>30</b>
Power Connections .....	30
Control Connections .....	30
<b>Installation Requirements.....</b>	<b>32</b>
Input Circuit Protection.....	32
Maintenance Bypass .....	32
Floor Requirements.....	32
Location .....	32
Power System .....	32
Electromagnetic Compatibility (EMC) .....	33
Harmonics .....	33
Downstream Capacitor Banks .....	33
<b>Service and Technical Support .....</b>	<b>34</b>
Comprehensive global services portfolio.....	34
Custom tailored service contracts.....	34
Life cycle management.....	34
Training.....	34
Engineering and technical support.....	34
<b>Additional Documents.....</b>	<b>35</b>

## VOLTAGE SAGS – THE PROBLEM

Modern industries are becoming more automated and the sensitivity of processes to power quality events is increasing. Although utilities endeavor to supply reliable, high-quality power, voltage sags and surges will continue to be a fact of life, even with modern power networks. Even a short event of less than one cycle can cause processes to unexpectedly stop, potentially resulting in product damage, wastage, and production shortages.

A voltage sag is not a complete interruption of power; it is a temporary drop below 90% of the nominal voltage level. Most voltage sags do not go below 50% of the nominal voltage, and they normally last from 2 to 10 cycles - or from 32 to 200 milliseconds.

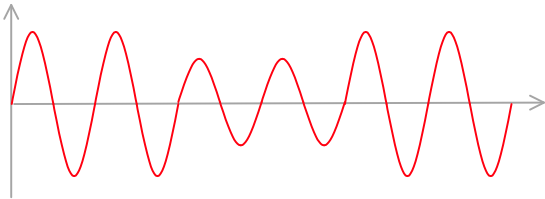

There are two sources of voltage sags: external, on the utility's transmission and distribution lines, and internal within the customer's facility.

Utilities continuously strive to provide the most reliable and consistent electric power possible. In the course of normal utility operations, however, many things can cause voltage sags.

Weather is the most common cause of external sags and momentary interruptions all around the world. Thunderstorms and lightning strikes on power lines create line to ground faults causing voltage sags in a wide area.



High winds can blow tree branches into power lines, connecting the line with the ground and shorting between phases. A series of sags will occur as the branches repeatedly touch the power lines.

Snow and ice buildup on power lines can cause flash overs on the insulators.



Other external causes are traffic accidents, construction works and animals impacting the power lines.

Internal causes of voltage sags can include starting major loads and grounding or wiring problems.

Whether or not a voltage sag causes a problem will depend on the magnitude and duration of the sag and on the sensitivity of your equipment. Many types of electronic equipment are sensitive to voltage sags, including variable speed drive controls, motor starter contactors, robotics, programmable logic controllers, controller power supplies, and control relays. Much of this equipment is used in applications that are critical to an overall process, which can lead to very expensive downtime when voltage sags occur.

# PCS100 AVC-40 ACTIVE VOLTAGE CONDITIONER

The ABB PCS100 AVC-40 is an inverter-based system that protects sensitive industrial and commercial loads from voltage disturbances, providing fast, accurate voltage sag and surge correction as well as

continuous voltage regulation and load voltage compensation. The PCS100 AVC-40 has been optimally designed to provide equipment immunity from power quality events on the supply network.

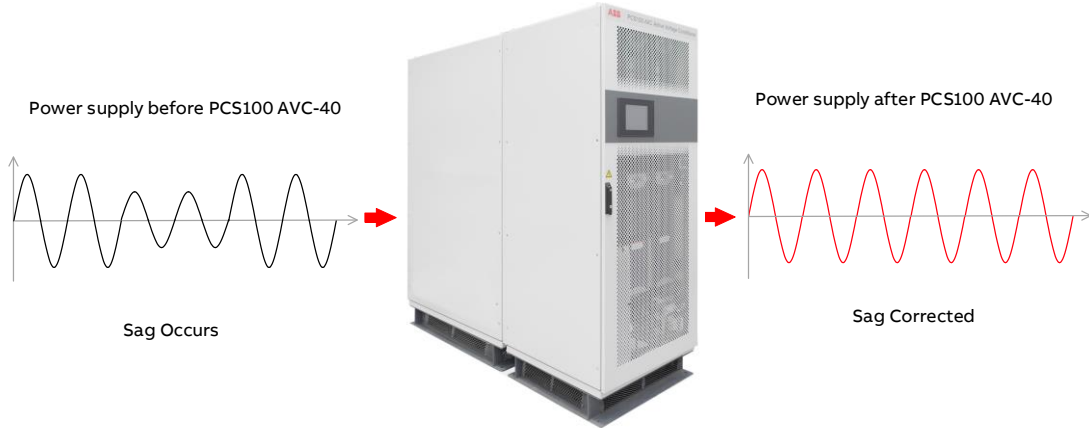

## How it works

The PCS100 AVC-40 consists of two converters that are not on the current path between the load and the utility. Instead, the corrective voltage injection is achieved by means of a transformer winding between the utility and the sensitive load. This configuration results in a very efficient and effective method to provide voltage correction with reduced risk of negative impacts on the load.

The PCS100 AVC-40 requires no batteries as it draws the additional energy required during sag to make up the correction voltage from the utility supply. With no ongoing maintenance costs typically associated with batteries the cost of ownership for PCS100 AVC-40 systems is very small.

Furthermore, the PCS100 AVC-40 contains a redundant internal bypass system that, in the event of overload or internal fault condition, ensures that the load is continued to be supplied from the utility

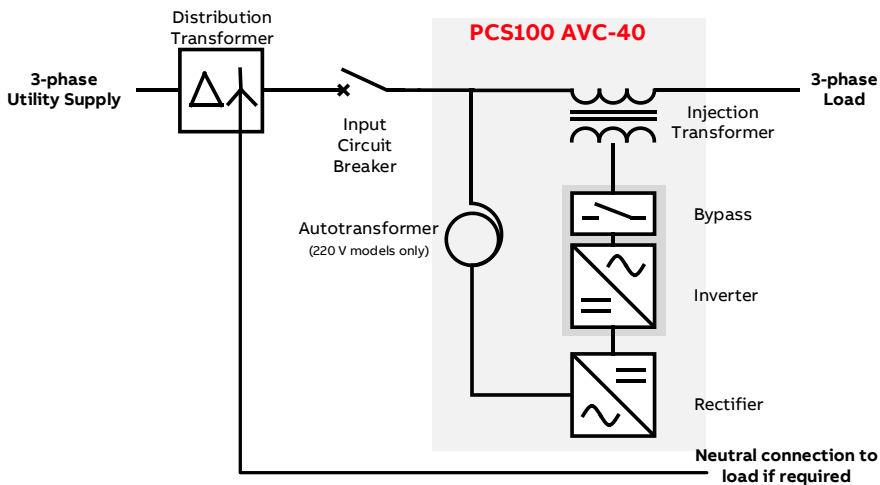

---

## PCS100 AVC-40 BENEFITS



### Reduce the cost of sag events

The PCS100 AVC-40 closes the electrical compatibility gap between the supply and plant by protecting the load from utility induced voltage sag events. The PCS100 AVC-40 minimizes the undue stress to the expensive equipment, thus increasing the equipment lifetime.

With high power capacity, the PCS100 AVC-40 is a perfect solution for industrial loads using significant power as well as large commercial buildings where continuity of service is paramount. The PCS100 AVC-40 is designed to target voltage sag events while also providing protection against swells. Sag events is the major cause of lost production.

### Improve plant operation

The PCS100 AVC-40 regulates the voltage, removing long term undervoltage, overvoltage and voltage

imbalance to reduce waste and damage to the expensive equipment. It also removes voltage fluctuations, which can cause process variation, improving the quality of operation of the plant or the facility.

### Faster return on investment

With industry leading efficiency exceeding 98 percent the PCS100 AVC-40 requires minimal costs for electricity and cooling. With no energy storage the ongoing maintenance cost is minimized, resulting low total cost of ownership.

### Reduce damage to equipment

Protect expensive equipment by regulating the voltage to remove long term undervoltage, overvoltage and voltage imbalance

## INDUSTRIES AND APPLICATIONS

Industrial automation has reached very high levels of sophistication. Industrial plants and commercial equipment now use advanced technology, and this technology relies on a robust and continuous power supply. However, the utility grid is susceptible to unpredictable events, such as lightning strikes and faults, resulting in voltage sags.

In the modern industrial world voltage sags cause disturbances in process and product defects. This results in wasted material, long restart times, extensive repair or maintenance activities, revenue

losses or contractual penalties. The costs of such events can quickly amount to hundreds of thousands of dollars.

Nowadays, almost all continuous production lines and process industries or sensitive medical equipment must perform faultlessly on a continuous basis. Ensuring that equipment receives a stable, clean, continuous flow of power, even during major grid disturbances, is where the PCS100 AVC-40 comes in.

**PCS100 AVC-40 provides power protection of commercial and industrial loads**

**Electronics industry**

Sensitive machinery  
Clean room control



**Food and beverage**

High speed bottling  
Packaging lines  
Dairy processing



**Automotive**

Welding process  
Coating process  
Painting process

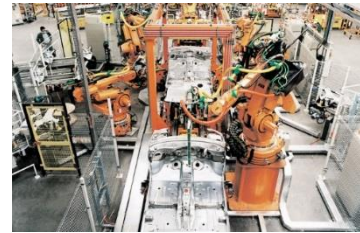

**Continuous process**

Fiber production lines  
Film production lines  
Extrusion process



**Pharmaceutical**

Batch process  
Climate control



**Medical**

Sensitive medical imaging  
equipment



## FEATURES



### No energy storage

Increased system reliability with minimized maintenance

### Very high efficiency

Typically, >98% even on partial loading

### Continuous online regulation

Continuous regulation within  $\pm 10\%$  with response less than 250  $\mu\text{s}$  and correction in less than  $\frac{1}{2}$  cycle

### Industrial design

Rugged overload capability, industrial grade fault capacity, designed for industrial loads

### Small footprint

Industry leading power density

### Regenerative load support

Bidirectional power module design allows connection of regenerative loads such as lifts and cranes

### Internal bypass

Redundant internal bypass design guaranteeing continuity of load supply in case of PCS100 AVC-40 fault

### Connectivity

Ethernet  
Modbus TCP  
Integrated web server  
E-mail notifications

### Modular construction

Proven PCS100 power converter platform, with more than 1800 MVA installed base, enabling fast and easy maintenance

### Sophisticated control software

Based on 20 years voltage conditioning industry experience

## FUNCTIONAL DESCRIPTION

### PCS100 AVC-40 Correction Capabilities

The PCS100 AVC-40 responds to voltage sags or swells within several milliseconds and can inject up to 40% voltage correction. If a facility was faced with a voltage sag to 60% of nominal voltage the PCS100 AVC-40 would boost the voltage back to 100%. Voltage sags with 50% of nominal voltage are corrected back to 90%. No process interruption, no equipment would trip, just business as usual.

Performance is even better for single phase sags (the most common type), voltage sags down to 40% of the nominal voltage are fully corrected. In case of deeper voltage sags, The PCS100 AVC-40 provides a partial tripping correction, which will often prevent loads tripping. In addition, it can continuously correct voltage fluctuations of  $\pm 10$  percent of nominal and remove imbalances.

Utility Supply Problem	Input	Output	Correction Time
Three-phase utility sags correction from	60% remaining supply voltage	100%	30 seconds
	50% remaining supply voltage	90%	10 seconds
	40% remaining supply voltage	70%	600 milliseconds
Single-phase utility sags correction from	40% remaining voltage	100%	30 seconds
	0% remaining voltage	57%	600 milliseconds
Single-phase utility swells correction from 115% voltage		100%	Continuous
Three-phase utility undervoltage to 90% of the nominal supply voltage		100%	Continuous
Three-phase utility overvoltage up to 110% of the nominal supply voltage		100%	Continuous
Correction of phase angle errors created by faults in the supply system		Yes	
Correction of voltage imbalance from utility supply		Yes	
Attenuation of flicker voltages in the utility supply		Yes	

# PCS100 AVC-40 Performance Curve

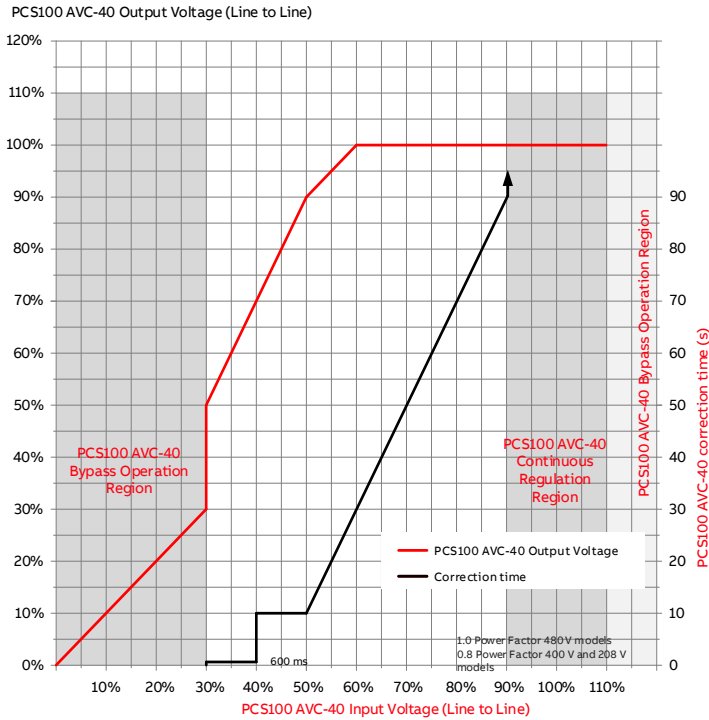

### Three Phase Balanced Events

The performance curves on the left apply to three phase balanced supply voltage disturbances upstream of the PCS100 AVC-40.

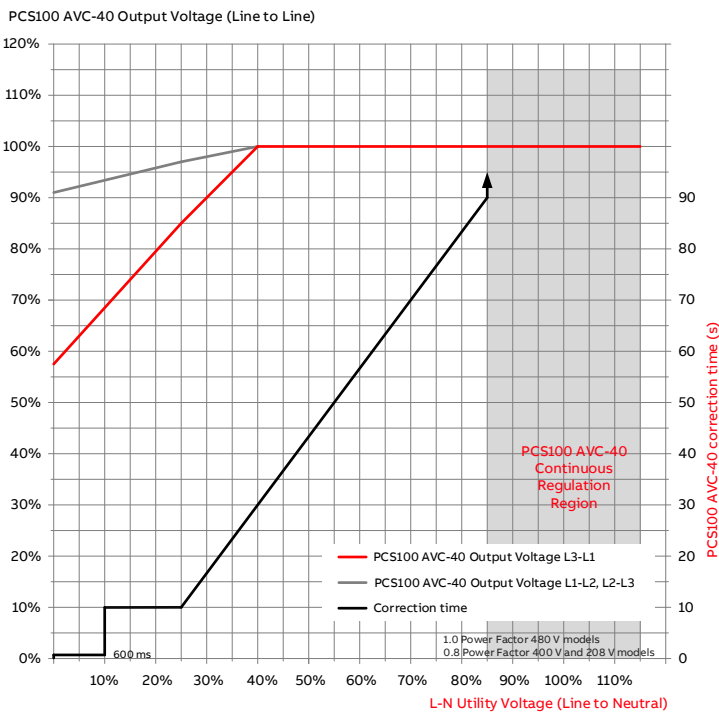

### Single-Line-To-Ground Events

The performance curves on the left apply to single-line-to-ground supply voltage disturbances upstream of the Dyn11 distribution transformer upstream of PCS100 AVC-40.

## PCS100 AVC-40 Operation Details

The following diagrams show the PCS100 AVC-40 operation when a utility disturbance occurs, and operation of the internal bypass.

### Utility Disturbance Occurs

When the utility voltage deviates from nominal or the set point due to a power quality event, the inverter will inject a correction voltage via the Injection Transformer. The correction voltage level is based on the disturbance level and the energy needed for correction is sourced from the utility via the PCS100 AVC-40 rectifier.

Diagrams on the right show cases with utility voltage below and above nominal level.

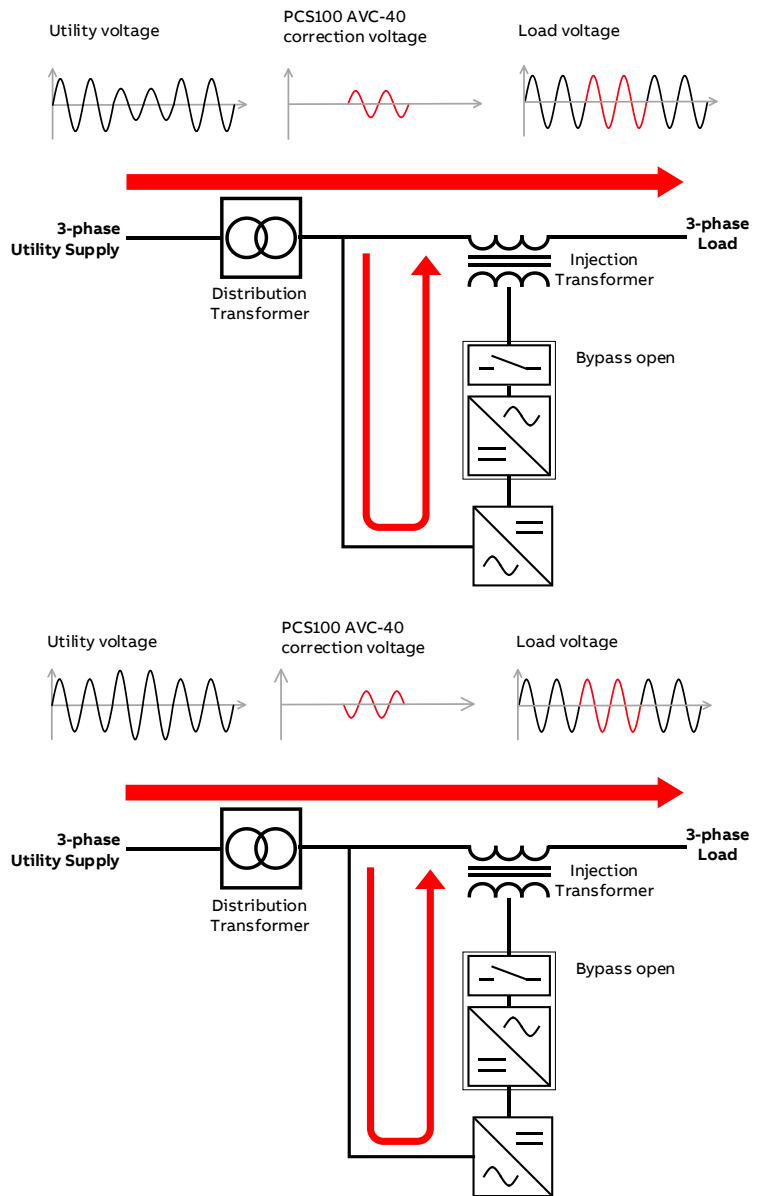

### Utility Voltage within Continuous Regulation Region

When the utility voltage is within continuous regulation range ( $\pm 10\%$ ), i.e., typical utility supply conditions without sags or surges, the PCS100 AVC-40 is only adding small corrections for utility voltage unbalance or load induced voltage variations.

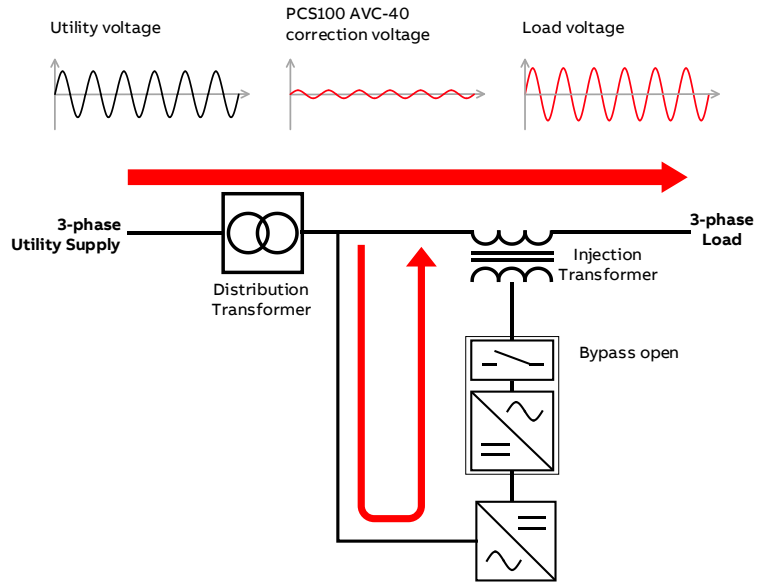

### Internal Bypass Operation

In the case of an overload or internal fault condition the internal bypass circuit will shunt the inverter side of the Injection Transformer, bypassing the inverter and effectively providing a direct connection from the utility supply to the output, without interruption to the load.

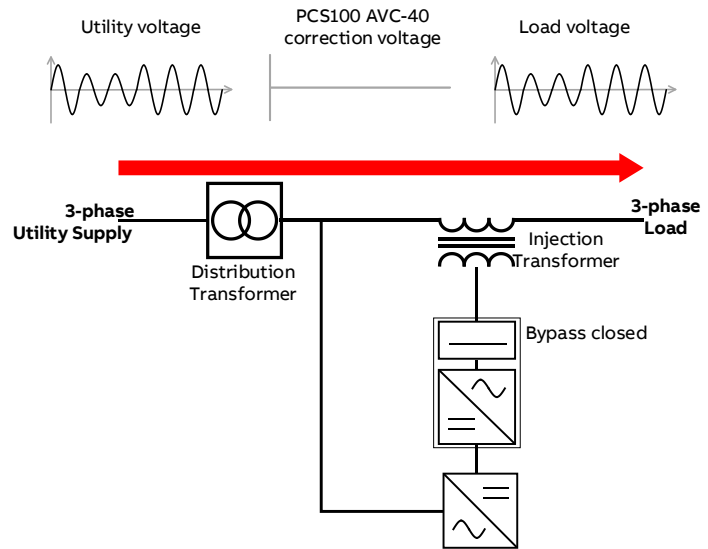

## TECHNICAL SPECIFICATION

### Utility - Input

Power range	450 – 1800 kVA (220 V model) 450 – 3600 kVA (400 and 480 V model)
Rated voltage (model specific)	220 V – application range 208 – 220 V 400 V – application range 380 – 415 V 480 V – application range 440 – 480 V
Maximum supply voltage	110%
Nominal supply frequency	50 or 60 Hz
Frequency tolerance	± 5 Hz
Power system	3-wire plus ground input (grounded wye source) + Neutral (4-Wire) <sup>1</sup> if required by load
Overvoltage category	III
Fault capacity	Refer to the model tables shown in this document
Outage – control ride through	600 ms
Harmonics <sup>2</sup>	IEC 61000-2-4 Class 2 (THDv < 8%)

### Load - Output

Voltage	To match nominal input voltage <sup>3</sup>
Equivalent series impedance	< 4% (model specific)
Displacement power factor	0 lagging to 0.9 leading <sup>4</sup>
Crest factor	3.0 <sup>5</sup>
Overload capability from 100% supply voltage	150% for 30 s, once every 500 s

### Performance

Efficiency	> 98% (Under Nominal Conditions)
Sag correction response	Initial < 250 μs Complete < ½ cycle
Voltage regulation accuracy	±1% typical, ±2% max.
Sag correction accuracy	±4%
Continuous regulation range	±10%
Sag correction performance <sup>6</sup>	
Three phase sags	60% to 100% for 30 s, 50% to 90% for 10 s
Single phase	40% to 100% for 30 s
Partial correction derating conditions <sup>7</sup>	1.0 PF at 80% load 0.8 PF at 100% load

### Internal Bypass

Capacity	100% of model rating (kVA)
Maximum overload capacity (in bypass)	125% for 10 minutes 150% for 1 minute 500% for 1 s 2000% for 200 ms
Transfer time	To Bypass < 0.5 ms To Inverter < 250 ms
Equivalent series impedance	bypass < 2.5% typical

<sup>1</sup> Neutral provided by supply transformer if required by the load. Neutral connection is not required to the PCS100 AVC-40.

<sup>2</sup> For THDv > 8%, please refer to factory. For applications where THDv is above 10% lifetime of components may be significantly affected, please refer to factory.

<sup>3</sup> Output voltage can be adjusted by ±10% with 0.1% steps

<sup>4</sup> Consult the factory if there is a power factor correction unit downstream

<sup>5</sup> Only applies at nominal load and for single phase loads

<sup>6</sup> Refer to performance curves in this document for more details

<sup>7</sup> Refer to document 2UCD070000E020 PCS100 AVC Detailed Performance Curves

**Injection Transformer**

Transformer type	Dry
Insulation	IEC 60085 Thermal class 200
Frequency	50 Hz and 60 Hz
Vector group	Diii (delta + 3 independent windings)

**Environmental**

Operating temperature range	0° C to 50° C (32° F to 122° F)
Temperature derating	Above 40° C (104° F), derate at 1.25% load per °C to a maximum of 50° C (122° F)
Operating altitude	<1000 m (3280 ft) without derating
Capacity derating with altitude	1% every 100 m (328 ft) above 1000 m (3281 ft) 2000 m (6562 ft) maximum
Inverter cooling	Forced ventilation
Transformer cooling	Natural convection
Humidity	< 95%, non-condensing
Pollution degree rating	2
Noise	< 75dBA @ 2 m (6.56 ft)

**Enclosure**

Enclosure rating	IP20/NEMA1 (IP21/NEMA2with optional roof kit)
Material	Electro-galvanized steel
Panel thickness	
Side and rear	1.5 mm
Door	2 mm
Finish	Standard epoxy-polyester powder coating textured finish
Color	RAL7035
Enclosure access	Hinged doors with key lock

**Service**

MTTR	30 min typical by module exchange
Diagnostics	Non-volatile event & service log
Remote monitoring	E-mail

**User Interface**

User interface	256.4 mm (10.1") color touch panel, multilingual
Touch panel	Full parameter control, system event log, voltage event log
Control inputs	Start / Stop / Reset digital inputs
Control outputs	Run, warning and fault relays
Communication	Ethernet Modbus TCP E-mail

**Power Quality Event Monitor**

Events recorded	Voltage Sag (RMS) Voltage Surge (RMS)
Measurement type	Half-cycle RMS according to IEC 61000-4-30
Event detection	Input Voltage
Sag threshold	90% of Utility voltage default setting (user adjustable)
Surge threshold	110% of Utility voltage default setting (user adjustable)
Accuracy	Voltage: ±2% Duration: 10 ms
Remote monitoring	Web server
Remote notification	E-mail notification

**Standards and Certifications**

Quality	ISO 9001
Environmental	ISO 14001
Marking	CE, C-Tick
Safety	IEC 62477-1
Electromagnetic compatibility	Emissions: CISPR 11 Class A Group 1 Immunity: IEC 61000-6-2
Performance	IEC 61000-4-34

## HOW TO SELECT A PCS100 AVC-40

To select the correct size of the PCS100 AVC-40 for the application the following information should be known.

- Utility voltage
- Power rating of the load (kVA and kW, or kVA and power factor)

The product tables in the following section can then be used to look up the required model for the given application. Each model has a specific type code.

### Type Code

The PCS100 AVC-40 type code is given in the product tables. The type code is a unique code for the specific PCS100 AVC-40 model and specifies all the components that are used to construct the model. From the base code given in the product tables options can be added to the type code. These options are called plus (+) codes.

The following diagram outlines the structure of the type code:

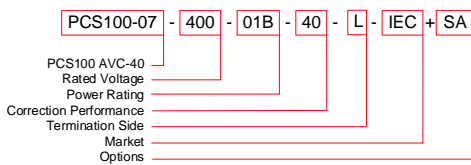

### Type Code Parameters:

#### Rated Voltage

This is the rated voltage of the PCS100 AVC-40. Options are 480 V, 400 V, and 220 V. Other operating voltages (e.g., 208 V or 380 V) are achieved by software settings and setting of an auxiliary transformer tapping.

#### Power Rating

Rated power of the system is based on the number of power module pairs. The power module pair operating on rated voltage provides 300 kVA of power<sup>8</sup>

#### Correction Performance

Defines sag correction performance. Correction performance of the PCS100 AVC-40 is 40%.

#### Termination Side

The location of the power terminals (input and output) when viewed from the front of the Transformer Enclosure<sup>9</sup>.

#### Market

Whether the system is for IEC or UL market. If UL is required contact the factory.

#### Options

Options as described in this catalogue are then added as plus codes to the main type code.

## PCS100 AVC Sizing Tool

In addition, ABB provides a Windows PC application PCS100 AVC Sizing Tool that can be used to dimension the correct PCS100 AVC-40 model required for the application.

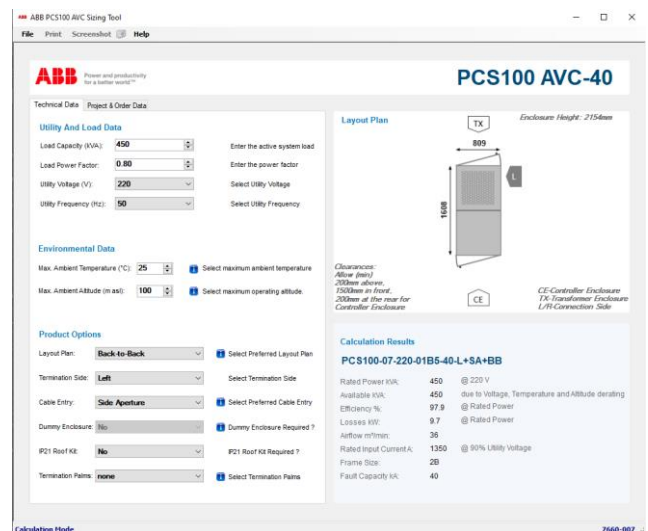

For further information and tool availability please contact your local ABB sales office.

<sup>8</sup> Operation at lower than the rated voltage results in less kVA per module pair. Consult the rating tables for more information.

<sup>9</sup> Without additional termination related options termination side can be from left, right or bottom as the transformer terminals are facing front.

## PCS100 AVC-40 MODEL RANGE

Rated power [kVA]		Rated Input Current [A] <sup>10</sup>	Rated Output Current [A]	Fault Capacity [kA]	Losses [kW] <sup>11</sup>	Efficiency [%] <sup>12</sup>	Airflow [m <sup>3</sup> /min]	Frame Size	Type Code Place R for right termination side or L for left termination side instead of x
<b>220 V Models</b>									
Utility Voltages									
220 V	208 V								
450	425	1350	1181	40	9.7	97.9	36	2B	PCS100-07-220-01B5-40-x
600	567	1791	1575	40	11.8	98.1	36	2B	PCS100-07-220-02B-40-x
750	709	2239	1969	50	14.5	98.1	54	3B	PCS100-07-220-02B5-40-x
900	851	2679	2362	50	16.4	98.2	54	3B	PCS100-07-220-03B-40-x
1200	1135	3567	3150	80	20.7	98.3	72	4B	PCS100-07-220-04B-40-x
1500	1418	4450	3937	100	25.2	98.4	90	5B	PCS100-07-220-05B-40-x
1800	1702	5331	4724	100	29.1	98.4	108	6B	PCS100-07-220-06B-40-x
<b>400 V Models</b>									
Utility Voltages									
400, 415 V	380 V								
450	427	742	650	31.5	8.9	98.1	36	2B	PCS100-07-400-01B5-40-x
600	570	985	867	31.5	10.8	98.2	36	2B	PCS100-07-400-02B-40-x
750	712	1232	1083	31.5	13.5	98.2	54	3B	PCS100-07-400-02B5-40-x
900	855	1474	1300	31.5	15.2	98.4	54	3B	PCS100-07-400-03B-40-x
1200	1140	1962	1733	40	19.1	98.5	72	4B	PCS100-07-400-04B-40-x
1500	1425	2448	2166	50	23.3	98.5	90	5B	PCS100-07-400-05B-40-x
1800	1710	2932	2599	63	26.8	98.6	108	6B	PCS100-07-400-06B-40-x
2400	2280	3938	3465	65	36.3	98.5	144	8B	PCS100-07-400-08B-40-x
3000	2850	4922	4331	65	47.7	98.4	180	10B	PCS100-07-400-10B-40-x
3600	3420	5906	5197	65	60.3	98.3	216	12B	PCS100-07-400-12B-40-x
<b>480 V Models</b>									
Utility Voltages									
480 V	440 V								
450	413	619	542	25	8.9	98.1	36	2B	PCS100-07-480-01B5-40-x
600	550	821	722	25	10.8	98.2	36	2B	PCS100-07-480-02B-40-x
750	688	1026	903	25	13.5	98.2	54	3B	PCS100-07-480-02B5-40-x
900	825	1228	1083	25	15.2	98.4	54	3B	PCS100-07-480-03B-40-x
1200	1100	1635	1444	40	19.1	98.5	72	4B	PCS100-07-480-04B-40-x
1500	1375	2040	1805	40	23.3	98.5	90	5B	PCS100-07-480-05B-40-x
1800	1650	2444	2166	50	26.8	98.6	108	6B	PCS100-07-480-06B-40-x
2400	2200	3281	2887	65	34.1	98.6	144	8B	PCS100-07-480-08B-40-
3000	2750	4102	3609	65	44.3	98.5	180	10B	PCS100-07-480-10B-40-x
3600	3300	4922	4331	65	55.4	98.5	216	12B	PCS100-07-480-12B-40-x

<sup>10</sup> At 90% utility voltage

<sup>11</sup> Typical value

<sup>12</sup> Typical value

# LAYOUT PLANS AND DIMENSIONS

## Layout Plans

### Side-by-side Layout Plans

The following plans relate to the standard Side-by-Side Layout of all frame sizes. Shown layouts are only for right (R) termination side. For left (L) termination side in Side-by-Side layout, the Transformer Enclosure is mounted on left side of Controller Enclosure.

#### 2B frame size<sup>13</sup>

Right termination side

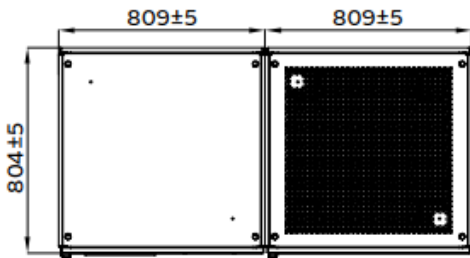

Top View

#### 3B frame size<sup>Error! Bookmark not defined.</sup>

Right termination side

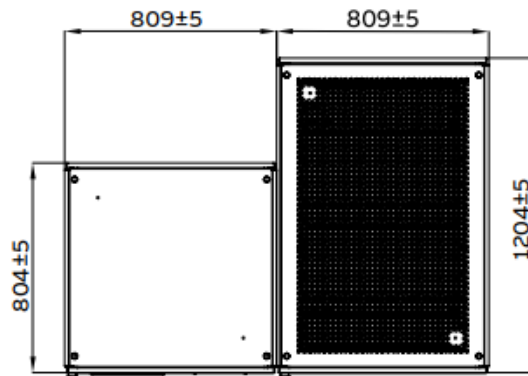

Top View

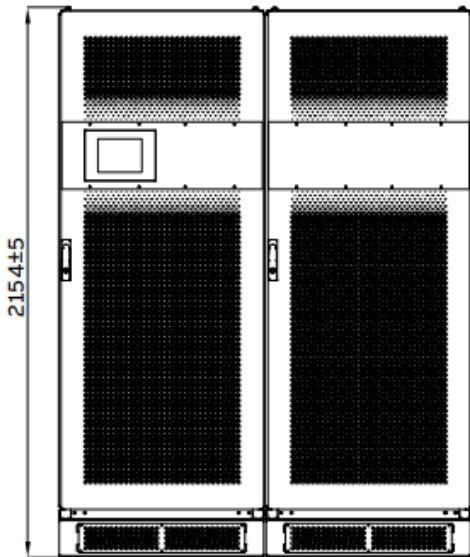

Front View

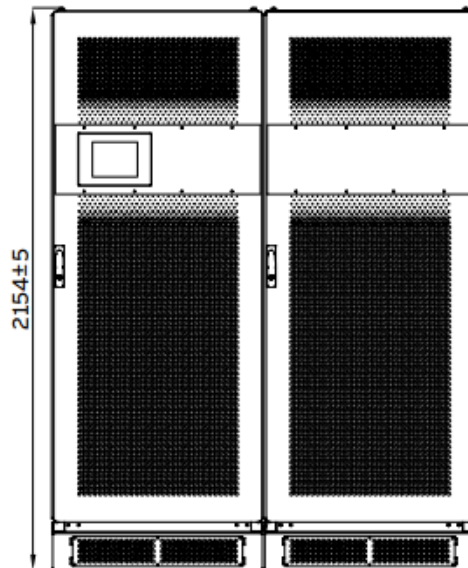

Front View

<sup>13</sup> For frame sizes 2B and 3B, due to position of Injection Transformer terminals, optional Termination Enclosure or Side Aperture MUST be selected. Please see Options chapter of this document for option description.

4B, 5B and 6B frame size  
Right termination side

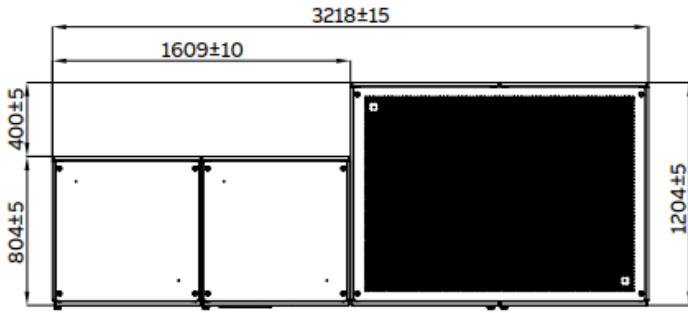

Top View

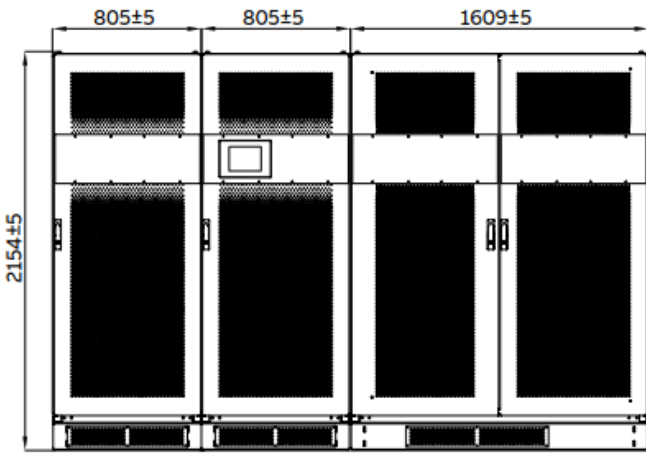

Front View

8B, 10B and 12B frame size  
Right termination side

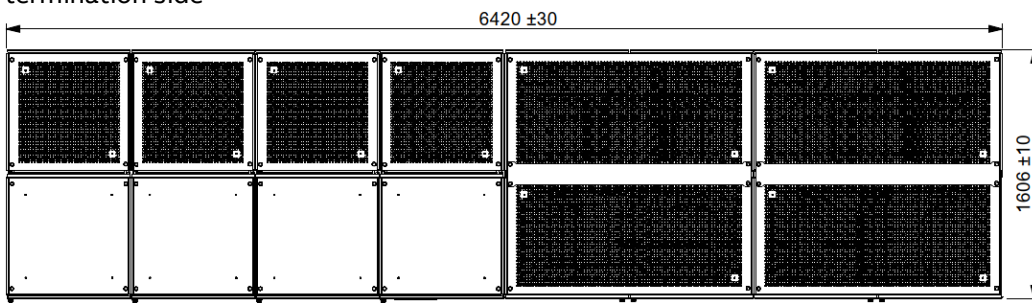

Top View

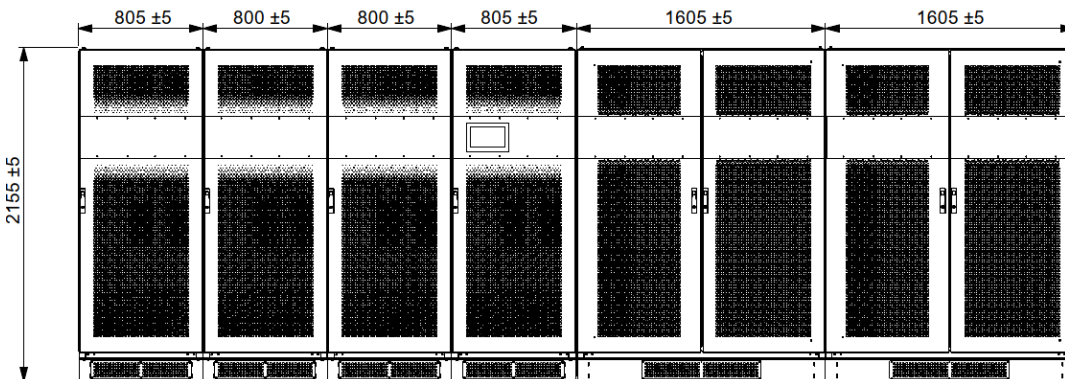

Slave 3  
Controller  
Enclosure    Slave 2  
Controller  
Enclosure    Slave 1  
Controller  
Enclosure    Master  
Controller  
Enclosure    Transformer 1  
Enclosure    Transformer 2  
Enclosure

Front View

**Back-to-back Layout Plans**

The following plans relate to the optional Back-to-Back layout with left (L) or right (R) termination side options shown. Exact termination side needs to be defined with L or R in the product type code.

**2B frame size<sup>14</sup>**

Right termination side

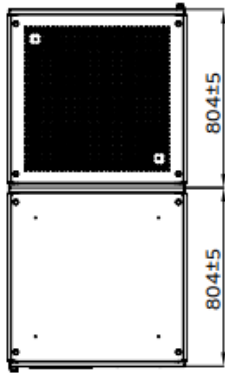

Top View

**3B frame size** Error! Bookmark not defined.

Right termination side

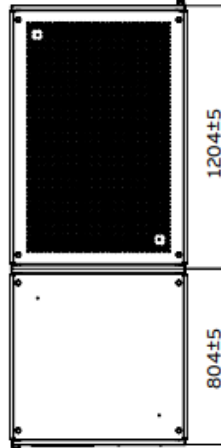

Top View

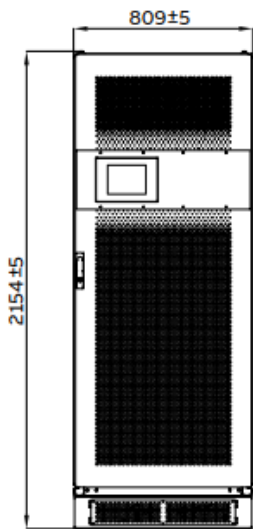

Front View

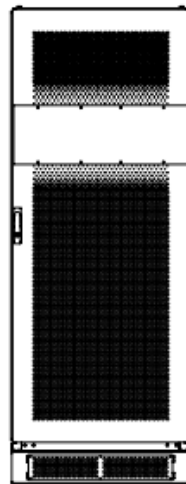

Rear View

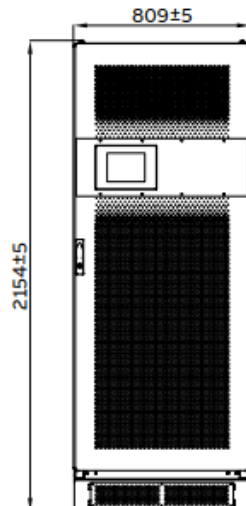

Front View

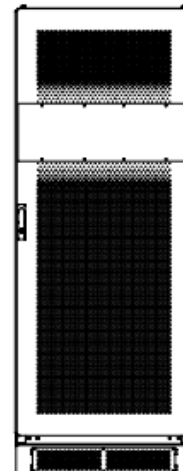

Rear View

<sup>14</sup> For frame sizes 2B and 3B, due to position of Injection Transformer terminals, optional Termination Enclosure or Side Aperture MUST be selected. Please see Options chapter of this document for option description.

4B, 5B and 6B frame size  
Right termination side

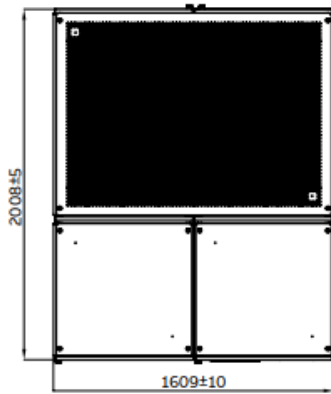

Top View

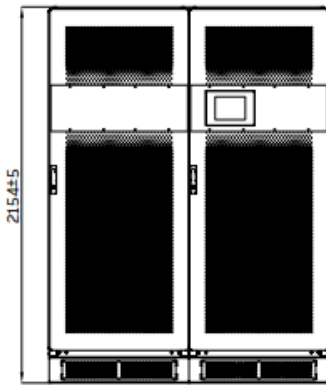

Front View

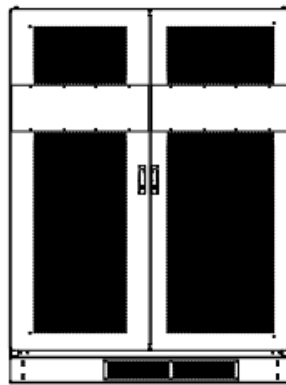

Rear View

8B, 10B and 12B frame size  
Right termination side

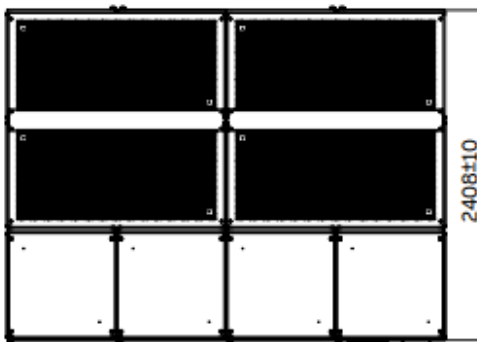

Top View



Front View

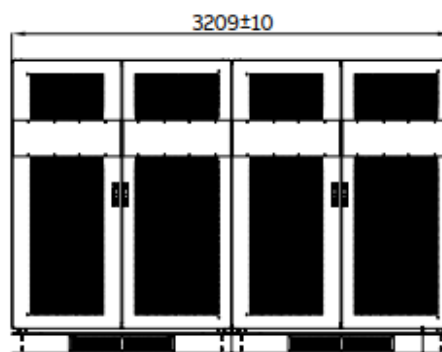

Rear View

## Clearance

The following clearances are required for all enclosures:

- Allow 200 mm (minimum above)
- Allow 1500 mm (recommended) clearance in front
- Allow 200 mm (minimum) clearance at the rear of Controller Enclosure for air flow. (Exception: The Transformer Enclosure can be placed back-to-back without any clearance.)

- No side clearance required
- Side clearance to the wall at the side where the cabinet outmost hinges of minimum 400 mm is recommended to allow the doors to open sufficiently. The doors must open 120° to allow normal cabinet access for the PCS100 AVC-40 module replacement.

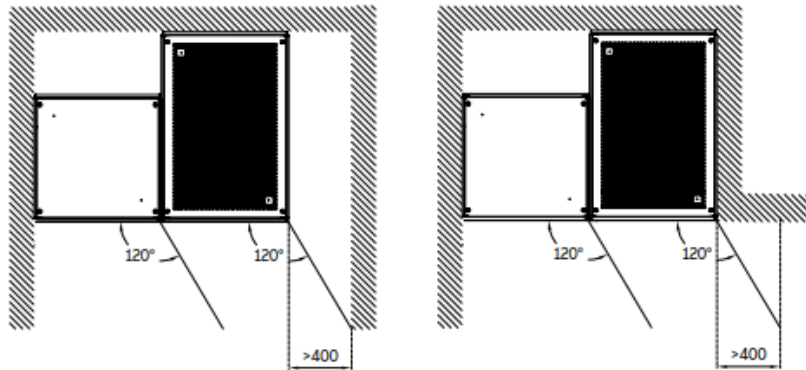

## Weights

The following tables show the dimensions and weights of Controller Enclosure and Injection Transformer Enclosure in different frame sizes<sup>15</sup>.

Frame Sizes	Controller Enclosure Dimensions (H×W×D)	Transformer Enclosure Dimensions (H×W×D)	Controller enclosure Weight 220 V models	Transformer Enclosure Weight 220 V models	Controller Enclosure Weight 400 and 480 V models	Transformer Enclosure Weight 400 and 480 V models
2B	2154x809x804 mm	2154x809x804 mm	581 kg	1520 kg	581 kg	1235 kg
3B	2154x809x804 mm	2154x809x1204 mm	714 kg	2380 kg	714 kg	1760 kg
4B	2154x1609x804 mm	2154x1609x1204 mm	1162 kg	3880 kg	1162 kg	2885 kg
5B	2154x1609x804 mm	2154x1609x1204 mm	1294 kg	3880 kg	1294 kg	2885 kg
6B	2154x1609x804 mm	2154x1609x1204 mm	1427 kg	3880 kg	1427 kg	2885 kg
8B	2154x3209x804 mm	2154x3209x1604 mm			2324 kg	7300 kg
10B	2154x3209x804 mm	2154x3209x1604 mm			2590 kg	7300 kg
12B	2154x3209x804 mm	2154x3209x1604 mm			2856 kg	7300 kg

<sup>15</sup> Allow ±10% tolerance for weights shown in the table

## OPTIONS

The following options are available for the PCS100 AVC-40 enclosures.

Plus Code	Option Description	2B	3B	4B, 5B, 6B	8B, 10B, 12B	Note
BB	Back-to-Back Layout Plan	X	X	X	X	
SA	Side Aperture	X	X	X		
CD	Top Entry Cable Duct	X				Termination palm recommended for 2B to ensure adequate space for cable connection
RK	Roof Kit	X	X	X		Not available with the Cable Duct or the Termination Enclosure options
TE	Termination Enclosure	X	X	X		
DMY	Dummy Enclosure	X	X	X		Back-to-Back layout only
TPx	Termination Palms	X	X	X		X = I for IEC or N or NEMA
PS	Redundant Power Supply Unit	X	X	X	X	

### Back-to-back Layout (BB)

PCS100 AVC-40 models larger than 300 kVA consist of Controller Enclosures and Transformer Enclosures. The standard layout is Side-by-Side where the Controller Enclosure and Transformer Enclosure are lined Side-by-Side. For optional Back-to-Back layout (+BB plus code) the Transformer Enclosure is installed behind the Controller Enclosure.

### Side Aperture (SA)

Left and right facing transformer enclosures are supplied with the complete side panel.

The enclosure can be supplied with an aperture pre-cut as pictured.

The side aperture allows for an easier side cable or bus bar connection to a maintenance bypass. For safety reasons this option must be selected only when there is a maintenance bypass next to the PCS100 AVC-40.

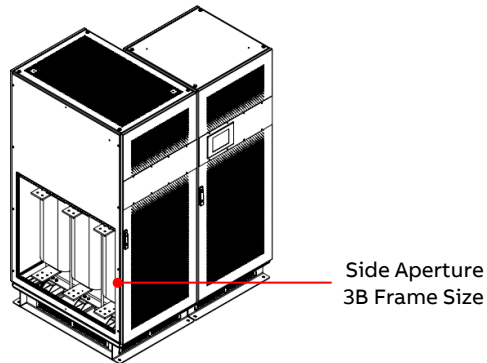

## Roof Kit (RK)

Roof Kits are available where small amounts of liquid may fall onto the top of the enclosures.

The roof kit option increases the units' protection degree to IP21/NEMA2. These are only for indoor use. There is a 200 mm clearance from the enclosure top to the roof kit to allow for ventilation of the transformer enclosure.

The kits will cover both the transformer and controller enclosures. The roof kit is shipped separately and must be assembled on site

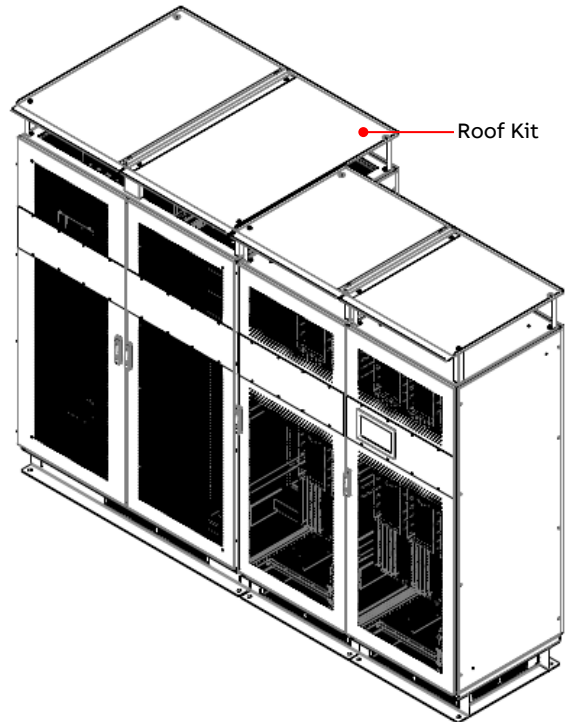

## Top Entry Cable Duct (CD)

200 mm Top Entry Cable Duct for supply and load cables (or bus bars) can be accommodated for frame sizes 2B.

The Cable Duct has the same depth as the PCS100 AVC-40 enclosure and is mounted on the side of the transformer terminals.

The Cable Duct comes complete with a top gland plate<sup>16</sup> and cable support.

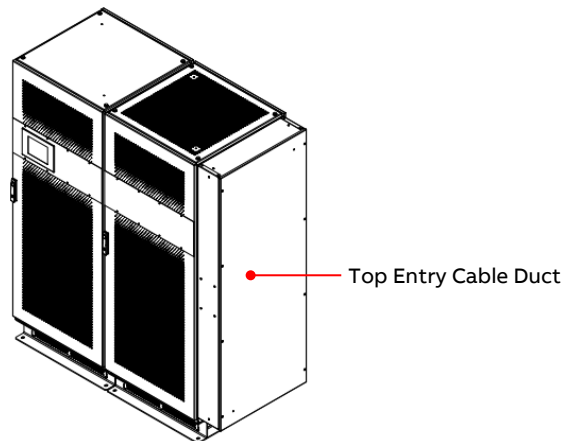

<sup>16</sup> The Gland Plate is delivered as a blind plate without any holes

## Termination Enclosure (TE)

The 400 mm Termination Enclosure option allows easier power connections or to match enclosure sizes with other equipment.

The Termination Enclosure has the same depth as the Transformer Enclosure and is mounted on the side of the transformer terminals.

The enclosure comes complete with a plinth and door access to enable top or bottom cable (or bus bar) connection.

The Termination Enclosure option includes cable support and gland plate.

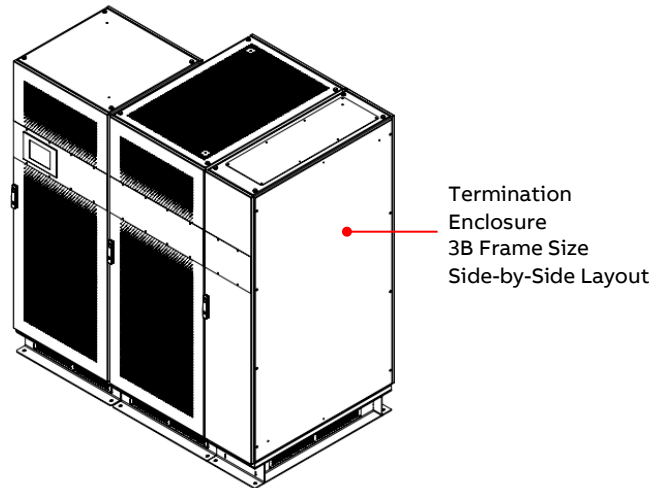

## Dummy Enclosure (DMY)

400 mm Dummy enclosures are completely empty enclosures that can be ordered for cosmetic reasons, e.g. to fill a gap between other enclosures in a Back-to-Back layout.

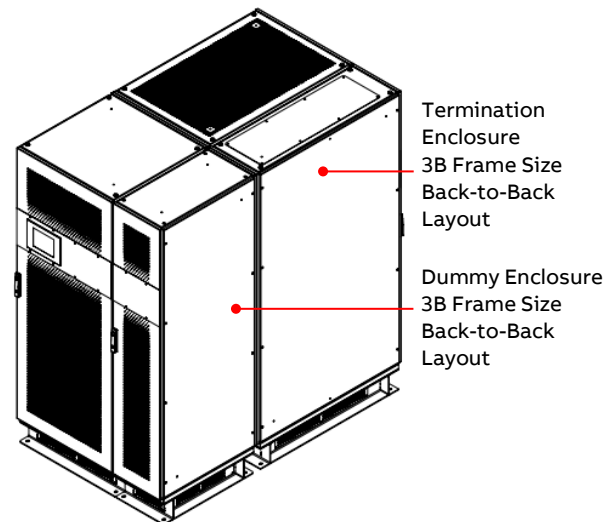

## Termination Palms (TPx)

Standard termination palms on the PCS100 AVC-40 are horizontal bars.

Termination Palms option offers vertical bars with dimensions and hole positions according to IEC or NEMA standard for all of the termination positions.

See example of standard offering and TPx option on the images below.

Add appropriate standard letter instead of x in TPx for correct option code:

- IEC standard TPI
- NEMA standard TPN

### Standard terminations

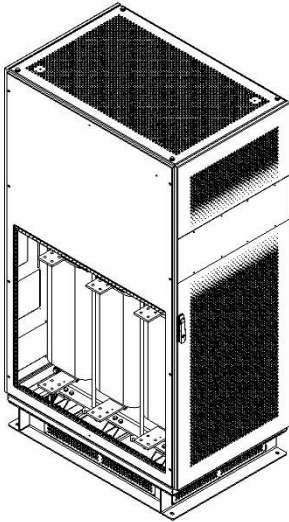

### TPx Termination Palms

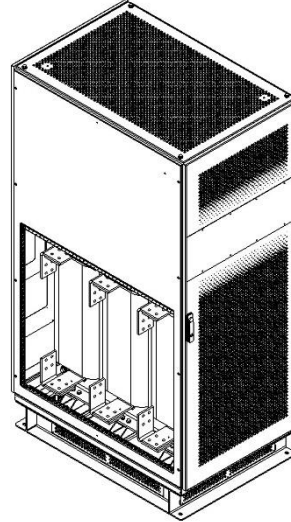

## Redundant Power Supply Unit (PS)

This option provides a new Auxiliary Master Module that contains two PSUs to provide redundant DC feed to the system.

The PSU has an internal status signal to indicate the status of each PSU. This signal is monitored and will

provide a warning 364 Redundant Aux Power if either PSU fails. The redundant PSU is designed such that the two PSUs share the DC supply of the system. If one PSU fails, the other will take over and supply all the modules

## USER INTERFACE

### Graphic Display Module

The primary user interface for configuration of the PCS100 AVC-40 is via the Graphic Display Module (GDM). The GDM is a 10.1” touchscreen user-friendly intuitive interface. The integrated navigation screen gives easy accessibility to any information on the PCS100 AVC-40, shows the system status and provides access to the operating parameters and

event history. The mimic diagram gives the users a clear view of the status of the system.

The supported languages are English, French, Italian, Malaysian, Turkish, Russian, German, Vietnamese, Spanish, Simplified Chinese, Japanese, Traditional Chinese, Swedish, Indonesian, Portuguese, Arabic and Korean.

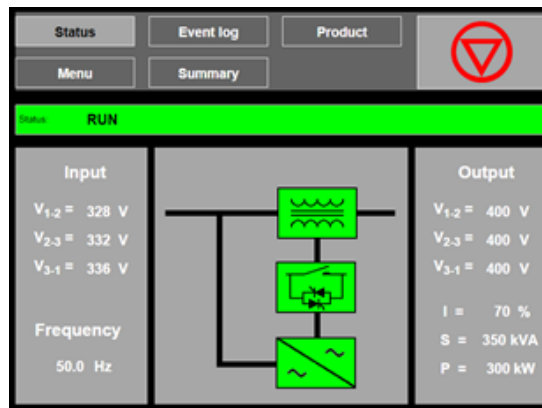

Features	GDM
Display resolution	1024 × 600 pixels
Display size	10.1”
Color graphic display	yes
Touch sensitive display	yes
Full descriptions of status and faults	yes
Local Start/Stop Reset Control	yes
Status Display	yes
Parameter adjustment	yes
Number of Event Log records stored	10,000
Event log can be downloaded to a PC	yes
Remote Web Pages	yes
Modbus TCP connection	yes
Multilanguage selection	yes
E-mail monitoring	yes

### Remote Monitoring

The GDM provides remote access for monitoring purpose. The following monitoring connections are available.

Communication Type	Description	Connection
Remote Web Pages	HTML server - Ethernet connection	Standard RJ45
Monitoring system	Modbus TCP	Standard RJ45
Remote notifications	E-mail	Standard RJ45

## Remote Web Pages

The Remote Web Pages are a set of web pages that are similar in format to the standard GDM and can be viewed with any standard web browser on a device connected to the same network. Through this interface the users can remotely access the status

and operating parameters. Viewing and downloading of the event history and service logs is also available. The Remote Web Pages enable users to select different languages for each remote client.

## Modbus TCP

A Modbus TCP connection is also provided via the Ethernet port of the GDM user interface. Read Only

access is available to operating parameters such as voltages, currents and power levels.

## E-mail

The PCS100 AVC-40 is configurable for sending e-mail notifications in case of power quality events or systems internal events such as faults and warnings.

Automatic sending of the service logs via e-mail to ABB Service can also be enabled.

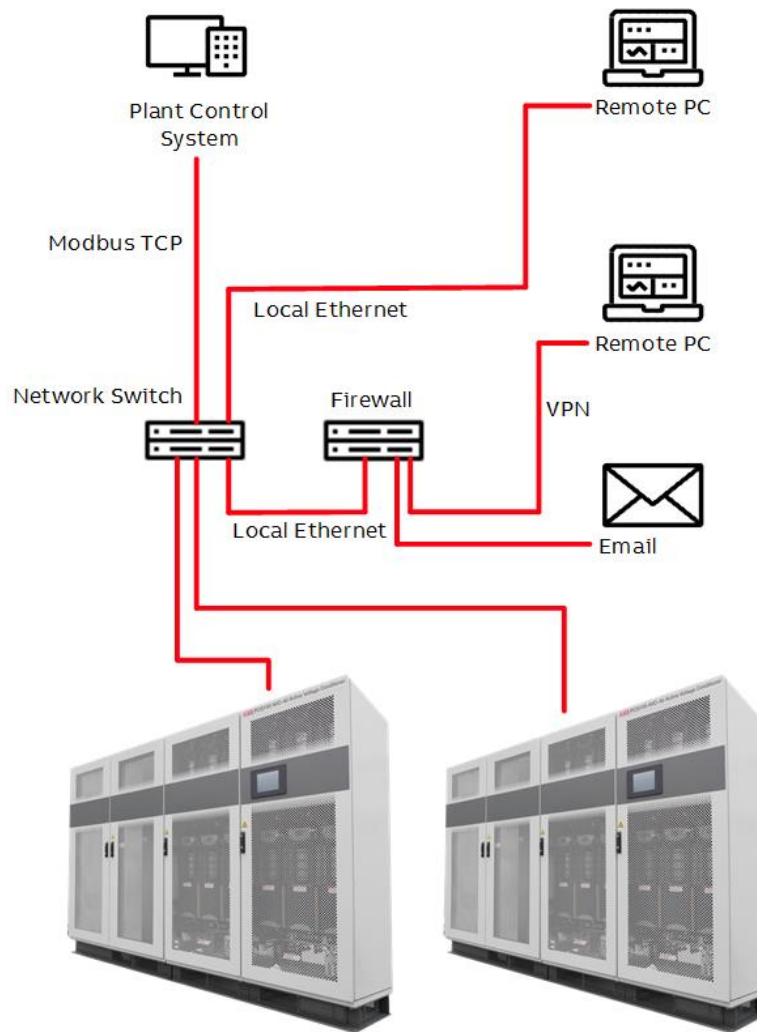

# USER CONNECTIONS

## Power Connections

The PCS100 AVC-40 utility supply (input) and load (output) connections are connected directly to the Injection Transformer terminals in the Enclosure.

The following table defines connection sides.

Transformer terminals	Connections
Top terminals	Utility Supply (Input)
Bottom terminals	Load (Output)

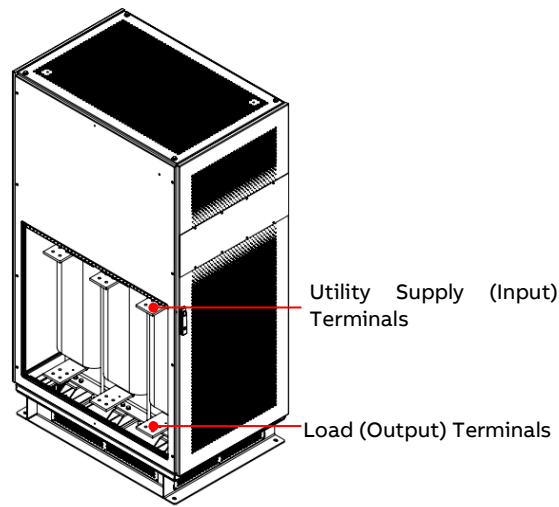

## Control Connections

The PCS100 AVC-40 includes control connections for local control or monitoring of the system. Control

connection terminals are located on the Auxiliary Master Module in the Master Controller Enclosure.

Control Connection	Description
3 Relay Outputs	PCS100 AVC-40 status information 250 VAC/30 VDC, 1 A
1 Isolated Thermal Switch	Transformer over temperature information 24 VDC/24 VAC, 1 A Normally closed (NC) contact
2 Digital Inputs	PCS100 AVC-40 Remote control Start/Stop/Inhibit Dry contacts

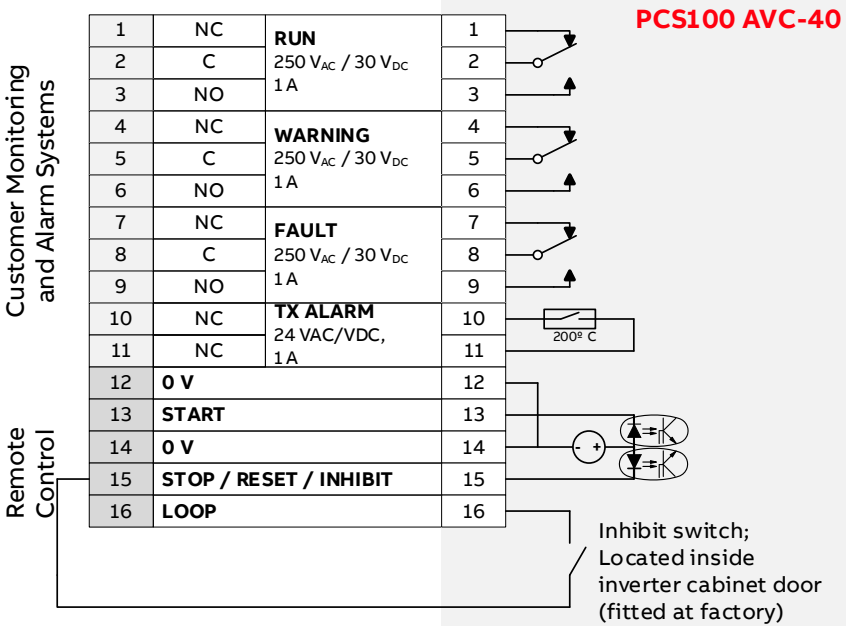

## INSTALLATION REQUIREMENTS

### Input Circuit Protection

The PCS100 AVC-40 relies upon upstream protection for current overload and short circuit protection. Upstream protection should be provided by a circuit breaker.

Overload protection must not be set greater than the PCS100 AVC-40 rated load current. Short circuit and arc fault calculations should include allowance for the additional PCS100 AVC-40 impedance (typically < 2.5%). Circuit breakers should be set to trip without any delay on short circuit or arc fault currents.

Coarse ground fault detection is recommended for high current systems where it may be difficult to assure ground or arc fault currents of sufficient magnitude to instantaneously trip the breaker.

The PCS100 AVC-40 unit is designed to withstand significant short circuit current. Typical short circuit withstand ratings are summarized in the model tables and also in the table below. The smaller systems in the table rely on fault current limiting protection from upstream circuit breakers or fuses provided by the customer.

Frame Size		2B	3B	4B	5B	6B	8B	10B	12B
Rated Power	[kVA]	600	900	1200	1500	1800	2400	3000	3600
208 V models	[kA]	40	50	80	100	100	N/A	N/A	N/A
400 V models	[kA]	31.5 <sup>Error!</sup> Bookmark not defined.	31.5 <sup>Error!</sup> Bookmark not defined.	40	50	63	65	65	65
480 V model	[kA]	25 <sup>Error!</sup> Bookmark not defined.	25 <sup>Error!</sup> Bookmark not defined.	40 <sup>Error!</sup> Bookmark not defined.	40	50	65	65	65

The PCS100 AVC-40 is rated to carry short duration fault currents to 2000% for 200 ms, and the upstream protection for small systems must be sized within this capability.

If required, the ABB factory can provide assistance with sizing appropriate protection. The PCS100 AVC-40 can sustain the fault currents listed above without damage and can be returned immediately to service following the fault. Where higher fault currents occur, service may be required following a downstream fault

### Maintenance Bypass

ABB recommends that a maintenance bypass (not supplied with the PCS100 AVC-40) is fitted. The maintenance bypass allows maintenance to be performed on the PCS100 AVC-40 without disruption to the load.

ABB requires the input and output breakers of a maintenance bypass to be lockable for an ABB service personnel to carry out any work on the PCS100 AVC-40. Please note that ABB LV breakers do not provide this as standard but as an option.

### Floor Requirements

All enclosures must be installed on a horizontal fireproof surface.

Do not exceed  $\pm 0.2^\circ$  change in slope between adjacent enclosures.

Do not exceed  $\pm 0.2''$  in elevation between adjacent enclosures.

### Location

The PCS100 AVC-40 is designed for location in a restricted access location only.

The PCS100 AVC-40 is designed for connection by fixed wiring.

The PCS100 AVC-40 system should be located in a clean electrical room with a controlled environment temperature and humidity according to the requirements under the Technical Specification section.

### Power System

The PCS100 AVC-40 is designed for TN-S power system where the upstream transformer provides neutral the load may require. Consult the factory for use in other earthing system.

## Electromagnetic Compatibility (EMC)

The PCS100 AVC-40 is designed for commercial and industrial applications. It is not suitable for connection to a low-voltage utility that is supplying residences unless additional measures are taken.

## Harmonics

The PCS100 AVC-40 is designed to tolerate disturbances such as voltage and current harmonics in the load or supply. Excessive distortion can lead to the stressing of components leading to reduction in the lifetime of the rectifier and inverter modules.

ABB recommends the harmonic contents on the input and the output of the system to meet IEC 61000-2-4 Class 2,  $THD_v$  up to 8%. Contact the factory for  $THD_v > 8\%$  as the lifetime of components may be affected.

## Downstream Capacitor Banks

A care must be taken when installing the PCS100 AVC-40 with a capacitor bank downstream of the system. ABB recommends the capacitor bank to be installed upstream of the PCS100 AVC-40. Contact ABB for more information.

## SERVICE AND TECHNICAL SUPPORT

ABB Power Conditioning provide global service and support of installation and commissioning of PCS100 products

### Comprehensive global services portfolio

ABB services span the entire product ownership life cycle:

- Pre-purchase engineering
- Installation and commissioning
- Technical support
- Training
- Preventive and corrective maintenance and maintenance spare parts kits
- Retrofit and refurbishment
- Globally available, supported by regional service hubs and operating in more than 100 countries
- Spare part availability and stocking
- On-site repairs
- 24 x 365 local support line

### Custom tailored service contracts

- 24 x 365 local support line
- ABB services can be packaged into a custom service contract
- Tailored to the specific needs of each customer
- Contracts can be made at any stage of ABB product ownership

Service contracts provide customers with improved cost controls, increased operational efficiency, lower capital expenditures, and extend ABB product life time.

### Life cycle management

ABB's life cycle management model maximizes the value of the equipment and maintenance investment

by maintaining high availability, eliminating unplanned repair costs and extending the lifetime of the system. Life cycle management includes:

- Spare parts and expertise throughout the life cycle
- Efficient product support and maintenance for improved reliability
- Functionality upgrades to the initial product

### Training

- Product training includes installation, commissioning, and maintenance
- Training either at ABB Universities or at a customer site
- Training can be included in an ABB services contract

### Engineering and technical support

ABB's engineering team provides the necessary electrical, protective and monitoring equipment, delivering a high level of energy continuity and superior power quality in a safe and cost-effective system. The PCS100 is available in several capacities, depending on the scope of application.

- Pre-purchase engineering to help select and integrate ABB PCS100 products
- Customer assistance in sizing and modeling of systems
- Other life cycle engineering and technical support is available by phone, email, or on-site visits, or as agreed in an ABB services contract
- Redundant internal bypass design increases reliability and availability and is part of a proven family of global ABB products
- Scalable building block design

---

## ADDITIONAL DOCUMENTS

Document Number	Document Name
2UCD074000E001	PCS100 AVC-40 User Manual
2UCD074000E002	PCS100 AVC-40 Installation Checklist
2UCD074000E004	PCS100 AVC-40 Commissioning Checklist
2UCD070000E020	PCS100 AVC Detailed Performance Curves
2UCD070000E025	AVC in TT Power Systems AN
2UCD200000E007	PCS100 Environment Specification



<https://library.abb.com>

---

**ABB Ltd.**

111 Main North Road  
4110, Napier  
New Zealand

[abb.com/ups](http://abb.com/ups)

2UCD074000E002\_D



© Copyright 2016 ABB. All rights reserved.  
Specifications subject to change without notice.